



REVERSIBLE RIBBED AND GROOVED SOLID & WOOD GRAIN EFFECT COMPOSITE DECKING BOARDS

Quick Installation Instructions

These instructions are designed as a quick and simple guide to using our two composite decking ranges; reversible ribbed and grooved and woodgrain. Please ensure that you have also read and understood the Technical Data Sheet (available to download from our website) in full before commencing any construction projects.

Contact us today for a free quote or for more information:
Tel: 01698 842244 | Email: help@scotplastradecentres.co.uk

Substructure: Normally C16 or C24 grade 6" x 2" treated softwood.

Maximum Joist Spacing (centre to centre): Residential use: Must not exceed 455mm (330mm if at 45° angle). Please refer to the Load Span Table available on the website.

Airflow Requirements: Always allow for adequate ventilation under the deck, use larger gaps and air vents if the deck is to be sunken or enclosed (contact us for more detail).

Board Spacing: Minimum 5mm (increase this to 10mm for hot, humid, damp or poorly ventilated areas).

Butt Joint Gaps: 5mm in between boards and where a board meets a wall. If area is often hot, humid, damp or poorly ventilated, a 10mm gap to the wall must be left.

Fixing Method: Only use supplied 53mm stainless steel composite deck screws when fixing to either WPC bearers or a timber subframe. Screw holes must be countersunk with a Smart-Bit® which is available to order with the fixings. Fit decking over at least 3 joists with 2 screws at every joist point and decking must be screwed down 20-40mm in from the cut end of the board.

Drill & Countersink: A Smart-Bit® can be ordered with your decking that will pre-drill and countersink in one quick operation, designed specifically for composite decking.

Fascia Boards: When attaching fascia boards to the side of a deck, it is important to make sure they are screwed down every 200mm (with 2 screws) along their length. Please allow the same spacing between fascia boards as for decking boards - both for board spacing and butt joint gaps.

DO NOT:

- Lay the boards directly onto a non self-draining surface without consulting with our technical department first.
- Use hidden fixings or clips.
- Butt boards up end-to-end closer than the specified amount.

Reversible Composite Decking

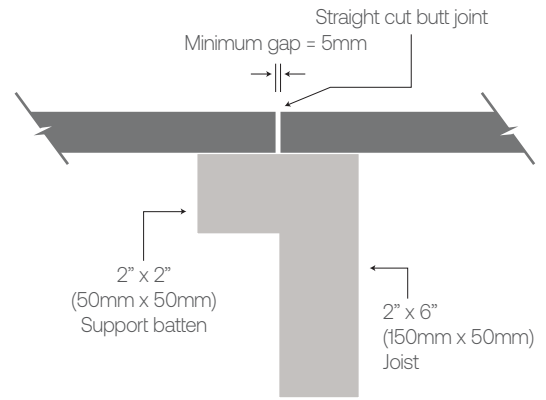
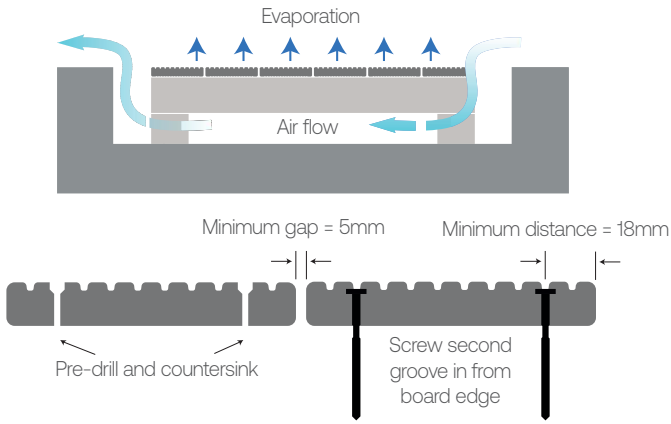

Mitre details suggestion

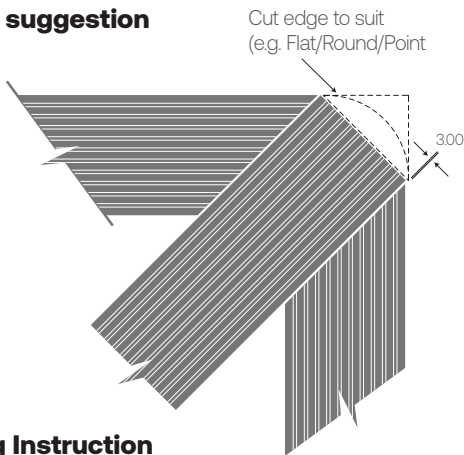

Screw Fitting Instruction

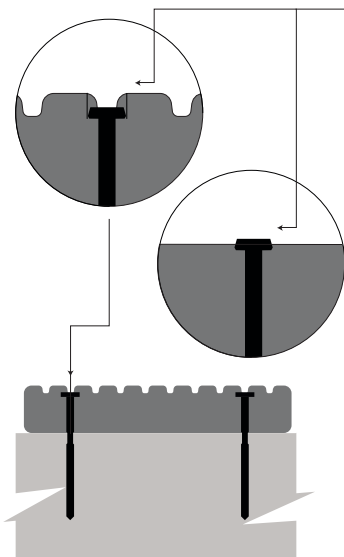

21MM GROOVED/RIBBED DECK BOARD
STRENGTH CHARACTERISTICS, AND SPAN
TABLE CAN BE FOUND ON OUR WEBSITE

Method of fitment:

1- Timber substructure (63mm Screws):

Pre-drill deck board with Smart-Bit®.

Composite substructure
(53mm Screws):

Pre-drill with a 3.5mm dia bit the full
depth of the screw

Steel substructure (38mm Screws):

Pre-drill with a 3.5mm dia HSS bit,

Pilot holes to be drilled second groove
in from edges of board

**2- Remove swarf residue (a 2-3mm
slice of deck board snapped in half to
give a rough edge makes a good swarf
removal tool)**

**3 - Preferably use an impact driver as
this prevents over-screwing**

**4 - Screw head will not go flush with
the bottom of the groove but it must
not protrude about the deck surface,
see the picture for detail**

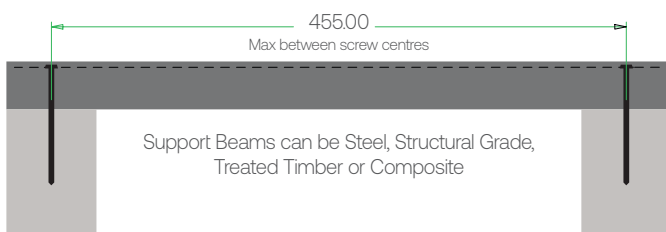

SUPPORT SPACING IS BASED UPON SPECIFIED LOADINGS
FOR RESIDENTIAL DECKS, BALCONIES AND WALKWAYS AS PER BS EN 1991-1-1:2002

'ACTIONS ON STRUCTURES - IMPOSED LOAD FOR BUILDINGS'



Unit 17
Darrows Industrial Estate
John Brannan Way
Bellshill
ML4 3HD

01698 842244

help@scotplastradecentres.co.uk

scotplastradecentres.co.uk



Due to the limitations of the printing process the swatches and photography in this leaflet should be taken as a guide and not an accurate representation of the actual product colour.